

NOTES:

1) PARTS NOT SHOWN

1.1) 10632 - BAND CLAMP (QTY - 2)

1.2) 31302 - WIRE HARNESS W/REMOTES & LIGHT (QTY - 1)

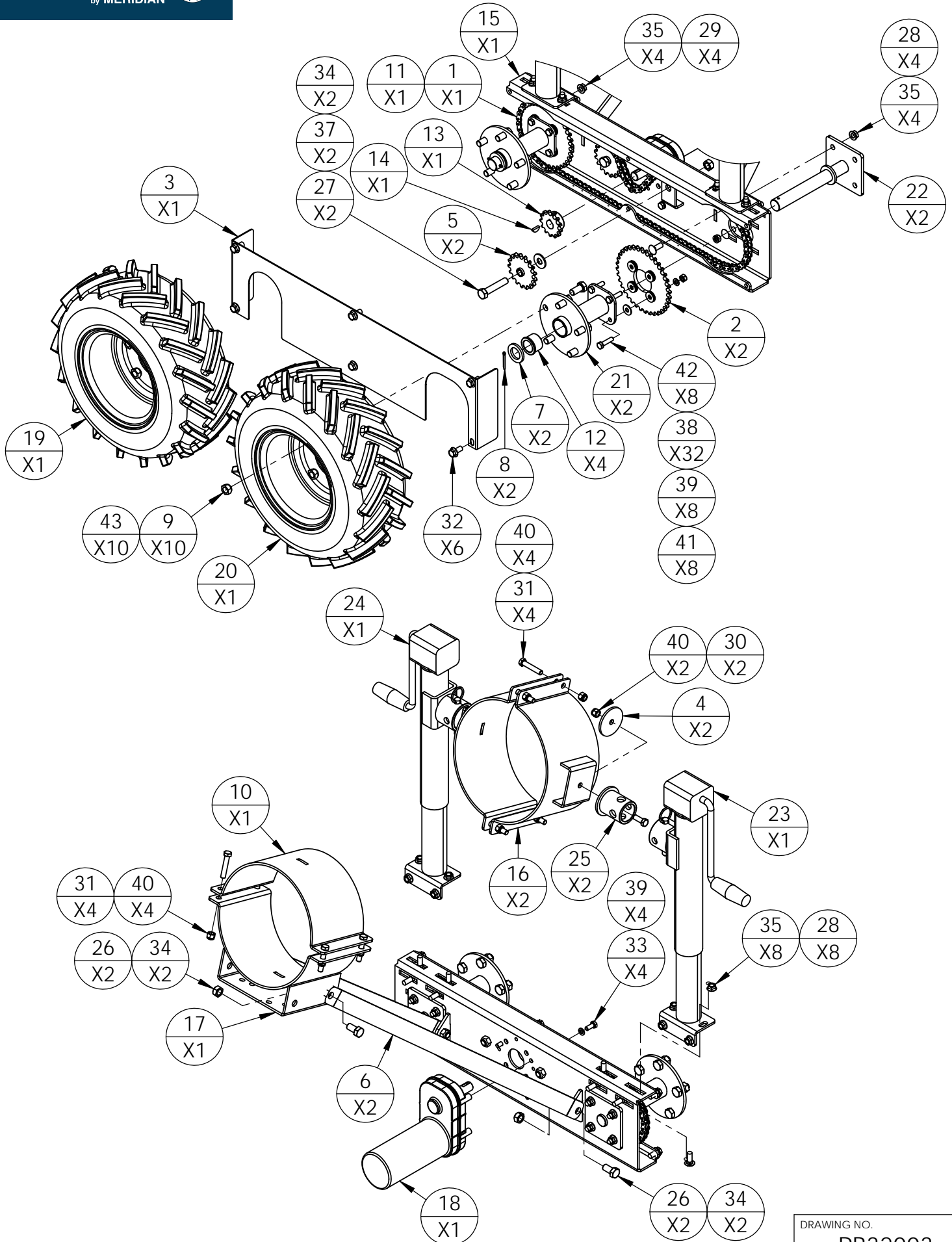

ITEM NO.	PART NO.	DESCRIPTION	QTY
1	10371A	CHAIN, HYD SWING, #40x126 ROLLERS, W/CONN LINK	1
2	10386	SPROCKET, HYDRAULIC WHEEL DRIVEN	2
3	10389	GUARD, HYDRAULIC WHEEL CHAIN	1
4	10393	PLATE, JACK TUBE SWIVEL MOUNT	2
5	10394	SPRCKT,IDLER, #40 CHAIN x 17 TOOTH, 1/2" BORE	2
6	10395	BRACE, HYDRAULIC SWING HOPPER DRIVE	2
7	10396	WASHER, HYDRAULIC WHEEL ALIGN	2
8	10426	PIN, COTTER, .125"x1.5"	2
9	10434	NUT, 1/2-20, 60 DEGREE LUG NUT, ZINC	10
10	10632	BAND CLAMP, 10"	3
11	11119	LINK, CONNECTOR, #40 ROLLER CHAIN	1
12	11672	BUSHING LIFT ROLLER, T1062 & 72	4
13	12056	SPROCKET, #40 X 13 TEETH, 3/4" BORE	1
14	12074	KEY, WOODRUFF, 3/16 X 3/4", #606	1
15	30147A	FRAME ASSEMBLY, HYDRAULIC WHEEL KIT	1
16	30306	CLAMP, ASSEMBLY, JACK MOUNT, HYD WHEEL, 10"	2
17	30307	CLAMP, ASSEMBLY, VALVE MOUNT, HYD WHEEL, 10"	1
18	31310	MOTOR, GEAR, 12V, SINGLE OUTPUT	1
19	31393	TIRE/RIM ASSY,16x6.5x8x5 ON 4.5, 3/4" OFFSET, RIGHT	1
20	31394	TIRE/RIM ASSY,16x6.5x8x5 on4.5, 3/4" OFFSET RIM,LEFT	1
21	31948	HUB ASM, HOPPER MOVER	2
22	31949	SPINDLE ASM, HOPPER MOVER	2
23	32017	JACK, HOPPER MOVER, LEFT	1
24	32018	JACK, HOPPER MOVER, RIGHT	1
25	32075	TUBE ASM, JACK MNT, SIDE WIND, HOPPER MOVER	2
26	40002	BOLT,1/2-13UNC X 1" HEX, GRD 5 , ZINC	4
27	40009	BOLT, 1/2-13UNC X 2-1/2" HEX, GRD 5, ZINC	2
28	40024	BOLT, 3/8-16UNC X 1" CARRIAGE, GRD 5, ZINC	12
29	40025	BOLT, 3/8-16UNC X 1" HEX FLANGE, GRD 5, ZINC	4
30	40026	BOLT, 3/8-16UNC X 1" HEX, GRD 5, ZINC	2
31	40028	BOLT, 3/8-16UNC X 2 HEX, GRD 5, ZINC	12
32	40030	BOLT, 3/8-16UNC X 3/4" HEX FLANGE, GRD 5, ZINC	6
33	40040	BOLT, 5/16-18UNC X 3/4" HEX, GRD 5, ZINC	4
34	40048	NUT, 1/2-13UNC, HEX, TOPLOCK, ZINC	6
35	40056	NUT, 3/8-16UNC, HEX FLANGE, GRD 5, ZINC	14
36	40059	NUT, 5/16-18UNC, HEX FLANGE, GRD 5, ZINC	2
37	40066	WASHER, FLAT, 1/2", ZINC	2
38	40069	WASHER, FLAT, 5/16", ZINC	32
39	40074	WASHER, LOCK, 5/16" SPLIT, ZINC	12
40	40095	NUT, 3/8-16UNC, HEX, NYLOCK, ZINC	14
41	40098	NUT, 5/16-18UNC, HEX, GRD 5, ZINC	8
42	40100	BOLT, 5/16-18UNC X 1-1/4", HEX, GRD 5, ZINC	8
43	40282	BOLT, 1/2-20UNF X 1", HEX, GRD5, ZINC	10