

TO: Valued Customers and Dealers  
RE: Gas Option Kit - HVST T1032  
DATE: 08-Nov-2018  
VERSION: N/A  
PART #: 13000008838

This **SERVICE BULLETIN** applies to the addition and/or modification of parts to the **Harvest T1032 Gas Option Kit**.

Failure to ensure that this procedure is completed will result in the **inability to install the Gas Option Kit on the Harvest T1032 Auger Assembly**.

**ALL** Customers **MUST** be informed upon purchasing their **Harvest T1032 Auger Assembly** that they must complete these modifications in order to operate the **T1032 Auger Assembly with the Gas Option Kit**.

These parts are required to complete the assembly of Harvest T1032 Auger Gas Option Kit as they were missing or incorrect from the First Production Run Hardware Boxes.

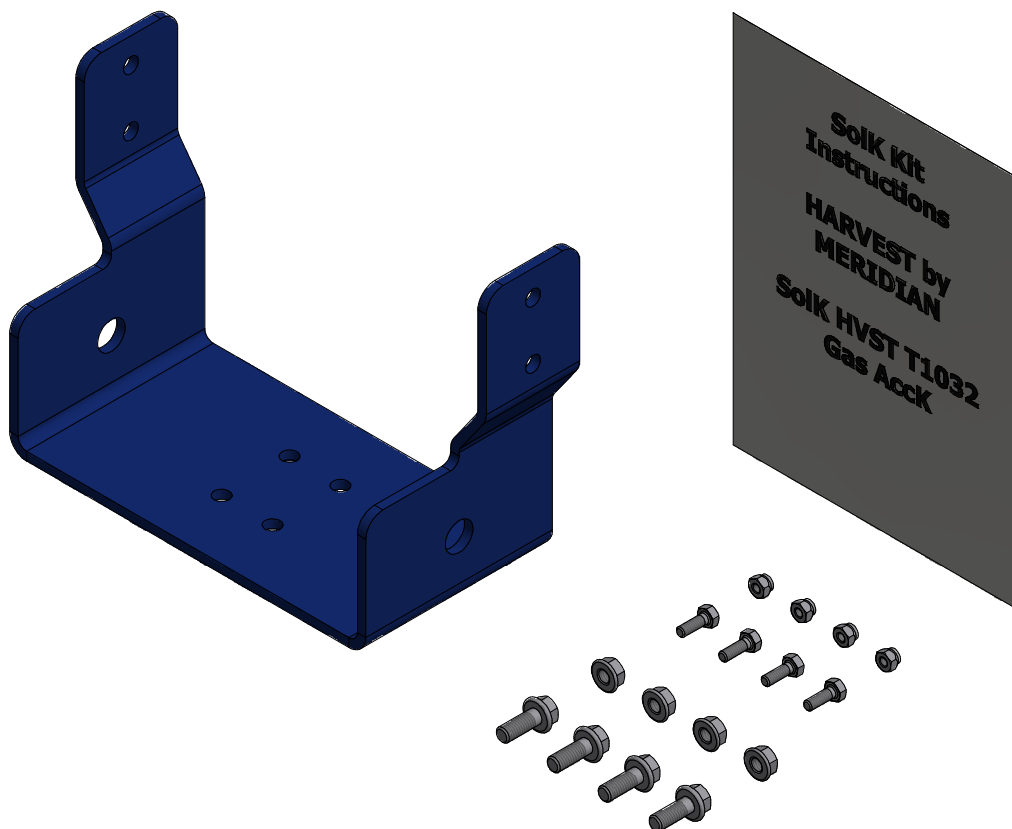

# Solk - HVST T1032 Gas Option Kit

Note: This kit will include the following components listed below. Ensure all components listed are included in the kit. If any parts are missing, contact Meridian Warranty @ 1-306-373-8448.

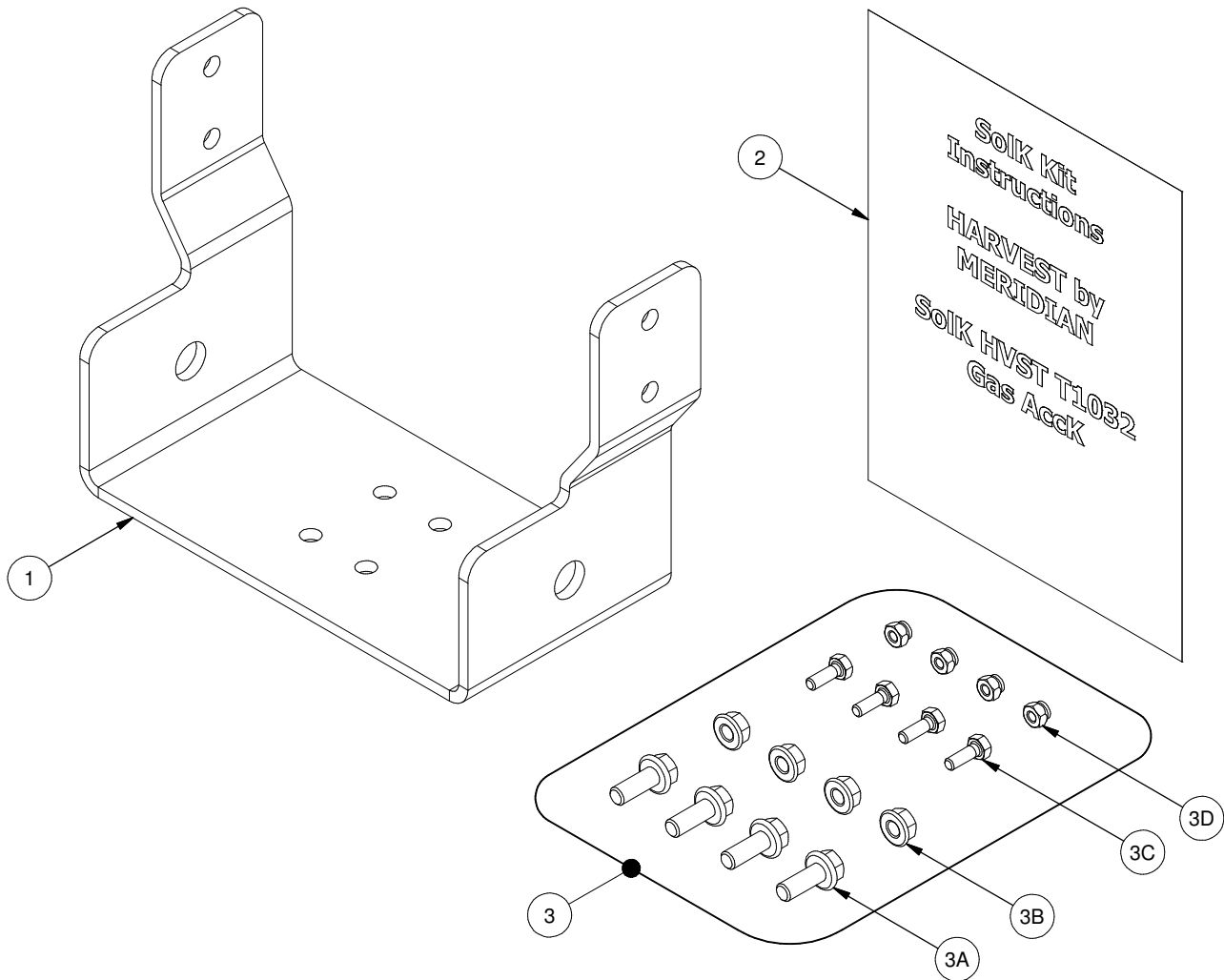

PARTS FOR: 1300008838			
REF #	PART #	QUANTITY	DESCRIPTION
1	1300060420-00	1	Bracket Mount Frame End Gas Option T1032
2	13000008838-01	1	Instructions Solk HVST T1032 Gas Option Kit
3	13000008839-00	1	Bolt Bag Solk HVST T1032 Gas Option Kit
3A	13071206016	4	BOLT, HEX, FLANGED, Steel, Mild 3/8-16 UNC X 1
3B	13073100006	4	NUT, HEX, FLANGED, Steel, Mild 3/8-16 UNC
3C	13070204012	4	BOLT, HEX, 1/4-20 UNC X 0.75 Steel, Mild
3D	13072900004	4	NUT, HEX, NYLOCK1/4-20 UNC Steel, Mild

# ASSEMBLY INSTRUCTIONS

READ AND UNDERSTAND ALL INSTRUCTIONS IN THIS SoIK ***BEFORE*** BEGINNING THE ASSEMBLY OF THE HARVEST T1032 AUGER GAS OPTION KIT. FAILURE TO DO SO WILL RESULT IN UN-NEEDED REWORK DISASSEMBLING AND REASSEMBLING THE HARVEST T1032 AUGER GAS OPTION KIT.

## Assembly Notes:

- i. Before starting assembly, check the parts list to ensure all components are present.
- ii. All bubbled item numbers refer to parts found in the Parts List of Page 2.

1. Fasten the Gas Option Frame Mount Bracket to the PTO Holder Brackets welded on the T1032 Intake Tube using (4) 3/8" x 1" Hex Flange Bolts and Flange Nuts from Bolt Bag 13000008839 included in this kit. See Figure 1. The Gas Option Frame Mount Bracket replaces Frame Mount Clamps (PN 1300031390) and (PN 1300010632) in HVST T1032 Gas Option Kit 13000PBT10062.

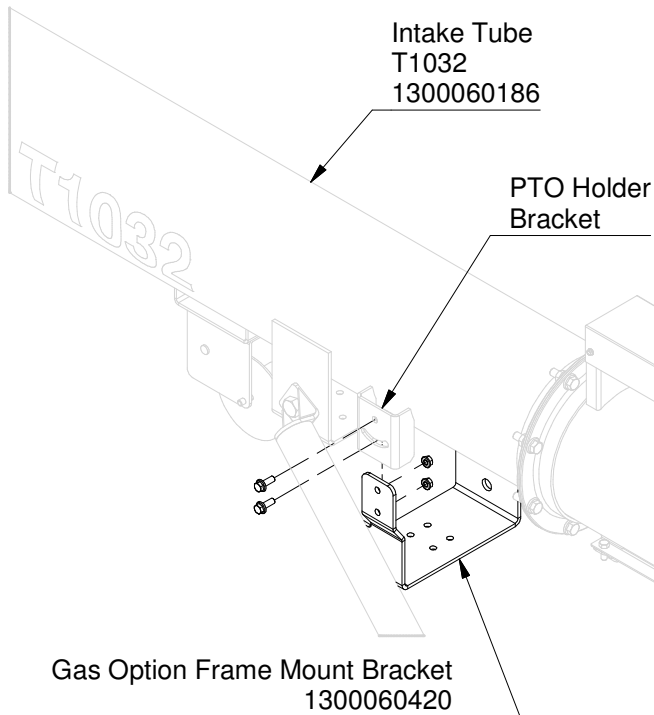

FIGURE 1

2. Return to the Main Assembly Instructions for the HVST T1032 Gas Option Kit 13000PBT10062 and continue assembling the Option Kit Frame as instructed. See Figure 2.

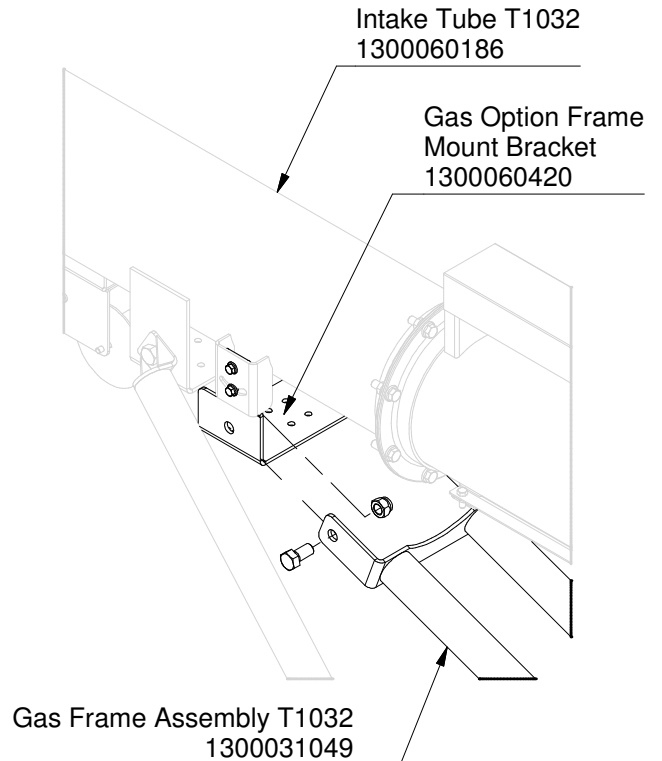

FIGURE 2

# ASSEMBLY INSTRUCTIONS

3. Before mounting the Latches to the Gas Inner Belt Guard, the holes must be drilled out to 9/32" dia. After drilling out the holes, fasten the Latches to the Gas Inner Belt Guard using (4) 1/4" x 3/4" Hex Bolts and Nylock Nuts from Bolt Bag 1300008839 included in this kit. See Figure 3. These fasteners replace the (4) Pop Rivets (PN 1300012017) in Bolt Bag 1300060242 found in HVST T1032 Gas Option Kit 13000PBT10062.

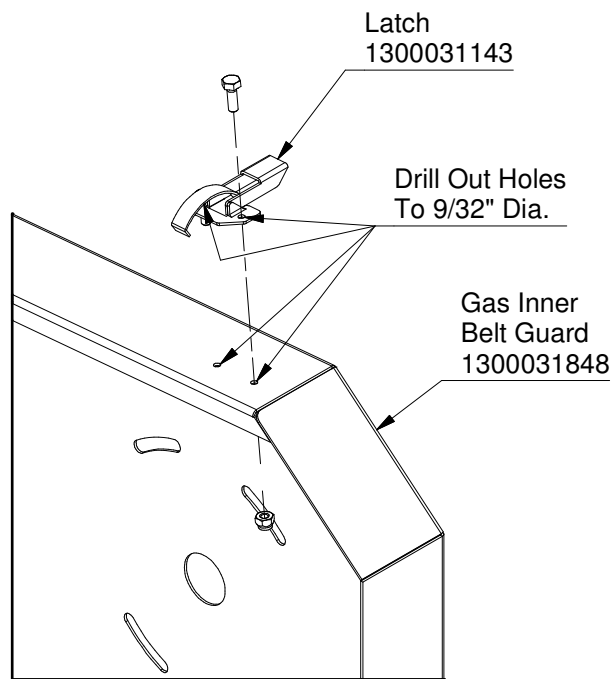

FIGURE 3

4. After the Gas Outer Belt Guard has been fastened to the Gas Inner Belt Guard, test the Latches to ensure they can clasp the Gas Outer Belt Guard easily and securely. If the Latch can't clasp the Gas Outer Belt Guard, then the clasp slot will need to be grinded until the Latch is able to clasp the Gas Outer Belt Guard. Only Grind in small increments and test the fit up consistently. Be careful to not over grind the clasp slots as the Gas Outer Belt Guard may become loose when clasped and the 2 Belt Guards will knock together when the Auger is in operation, creating unwanted knocking noises. See Figure 4.

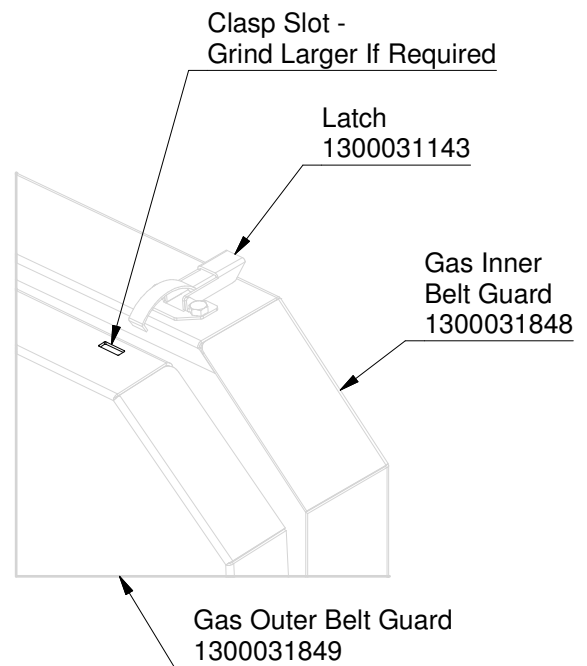

FIGURE 4

5. Return to the Main Assembly Instructions for the HVST T1032 Gas Option Kit 13000PBT10062 and continue assembling the Option Kit as instructed.